

GLASS PASSIVATED
SILICON BRIDGE RECTIFIER

VOLTAGE RANGE 50 to 1000 Volts CURRENT 1.0 Ampere

FEATURES

- * Glass passivated junction
- * Ideal for printed circuit board
- * Reliable low cost construction utilizing molded plastic technique
- * High temperature soldering guaranteed:
 260°C / 10 seconds /0.375"(9.5mm)
 leads length at 5 lbs., (2.3kg) tension
- * Small size, simple installation
 leads solderable per MIL-STD-202, Method 208

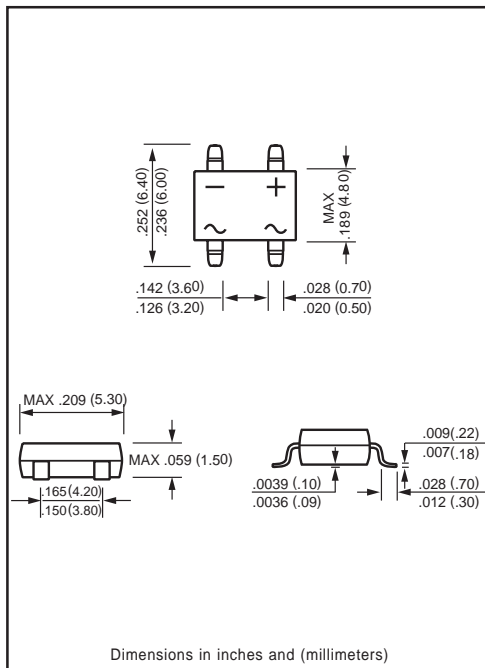

MAXIMUM RATINGS AND ELECTRICAL CHARACTERISTICS

Ratings at 25 °C ambient temperature unless otherwise specified.
 Single phase, half wave, 60 Hz, resistive or inductive load.
 For capacitive load, derate current by 20%.

MAXIMUM RATINGS (At TA = 25°C unless otherwise noted)

RATINGS	SYMBOL	SLDB101S	SLDB102S	SLDB103S	SLDB104S	SLDB105S	SLDB106S	SLDB107S	UNITS
Maximum Recurrent Peak Reverse Voltage	V _{RRM}	50	100	200	400	600	800	1000	Volts
Maximum RMS Bridge Input Voltage	V _{RMS}	35	70	140	280	420	560	700	Volts
Maximum DC Blocking Voltage	V _{DC}	50	100	200	400	600	800	1000	Volts
Maximum Average Forward Rectified Current On glass-epoxy P.C.B On aluminum substrate	I <sub(av)< sub=""></sub(av)<>	0.8 1.0							Amps
Peak Forward Surge Current 8.3 ms single half sine-wave superimposed on rated load (JEDEC method)	I _{FSM}	30							Amps
Typical Thermal Resistance	R _{θJA}	62.5							°C/W
	R _{θJL}	25							
Operating and Storage Temperature Range	T _J , T _{STG}	-55 to + 150							°C

ELECTRICAL CHARACTERISTICS (At TA = 25°C unless otherwise noted)

CHARACTERISTICS	SYMBOL	SLDB101S	SLDB102S	SLDB103S	SLDB104S	SLDB105S	SLDB106S	SLDB107S	UNITS
Maximum Forward Voltage Drop per Bridge Element at 0.5A DC	V _F	0.9							Volts
Maximum Forward Voltage Drop per Bridge	I _R	5.0							uAmps
DC Blocking Voltage per element		0.5							mAmps

Note: "Fully ROHS compliant", "100% Sn plating(Pb-free).

RATING AND CHARACTERISTIC CURVES (SLDB101S THRU SLDB107S)

FIG. 1 - MAXIMUM FORWARD CURRENT DERATING CURVE

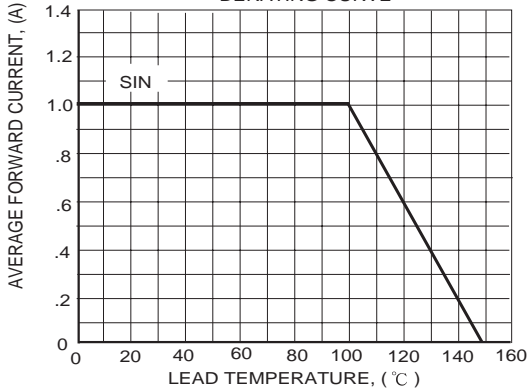

FIG. 2 - TYPICAL FORWARD CHARACTERISTICS

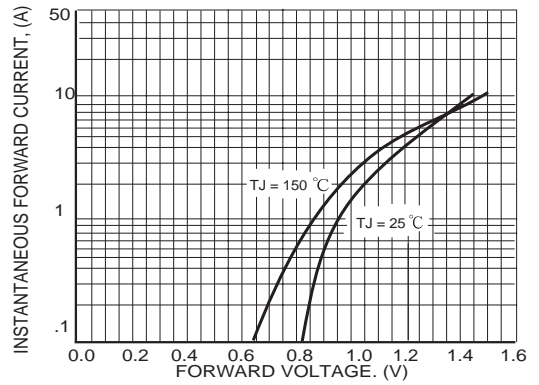

FIG. 3 - MAXIMUM FORWARD CURRENT DERATING CURVE

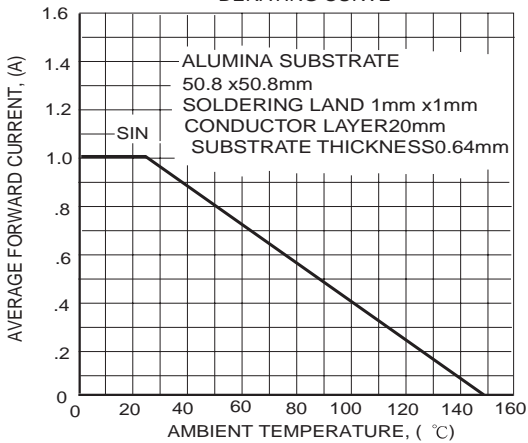

FIG. 4 - FORWARD POWER DISSIPATION

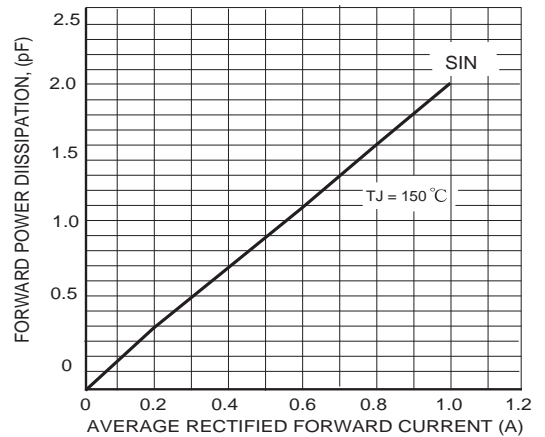
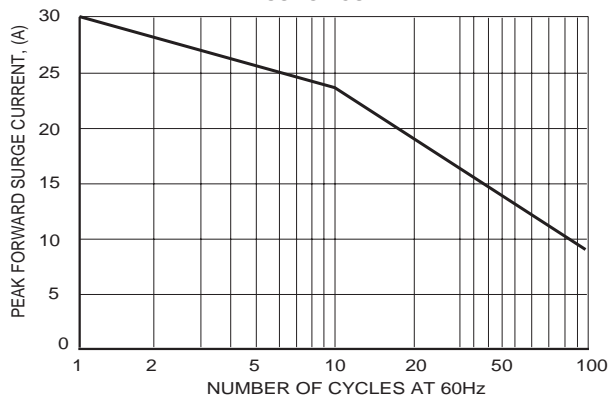
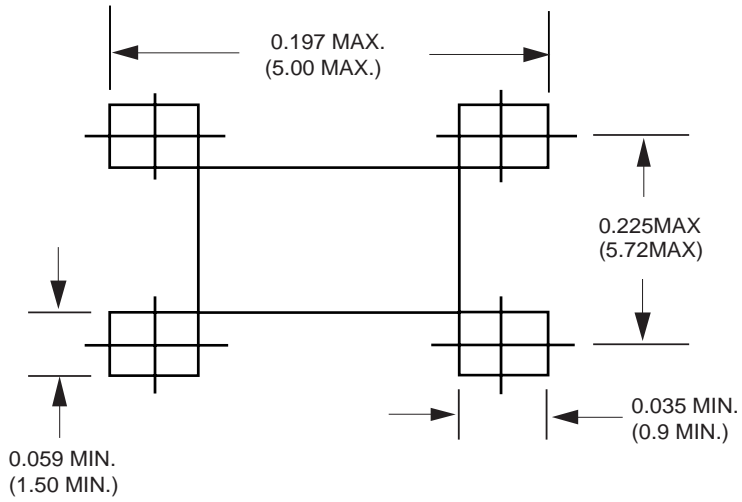

FIG. 3 - MAXIMUM NON-REPETITIVE FORWARD SURGE CURRENT



Mounting Pad Layout



Dimensions in inches and (millimeters)