

GLASS PASSIVATED SUPER FAST RECTIFIER

VOLTAGE RANGE 50 to 600 Volts CURRENT 2.0 Amperes

FEATURES

- * High reliability
- * Low leakage
- * Low forward voltage
- * High current capability
- * Super fast switching speed
- * High surge capability
- * Good for switching mode circuit

MECHANICAL DATA

- * Case: Molded plastic
- * Epoxy: Device has UL flammability classification 94V-0
- * Lead: MIL-STD-202E method 208C guaranteed
- * Mounting position: Any
- * Weight: 0.38 gram

MAXIMUM RATINGS AND ELECTRICAL CHARACTERISTICS

Ratings at 25 °C ambient temperature unless otherwise specified.
 Single phase, half wave, 60 Hz, resistive or inductive load.
 For capacitive load, derate current by 20%.

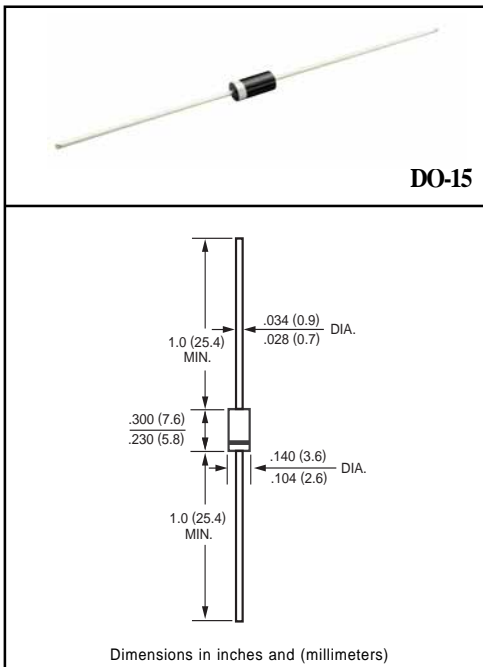

MAXIMUM RATINGS (At TA = 25°C unless otherwise noted)

RATINGS	SYMBOL	SF21	SF22	SF23	SF24	SF25	SF26	SF27	UNITS
Maximum Recurrent Peak Reverse Voltage	VRRM	50	100	150	200	300	400	600	Volts
Maximum RMS Volts	VRMS	35	70	105	140	210	280	420	Volts
Maximum DC Blocking Voltage	VDC	50	100	150	200	300	400	600	Volts
Maximum Average Forward Current TA = 55°C	Io	2.0							Amps
Peak Forward Surge Current IFM (surge):8.3 ms single half sine-wave superimposed on rated load (JEDEC method)	IFSM	75							Amps
Typical Junction Capacitance (Note 2)	Cj	30			20				pF
Operating and Storage Temperature Range	TJ, TSTG	-55 to + 150							°C

ELECTRICAL CHARACTERISTICS (At TA = 25°C unless otherwise noted)

CHARACTERISTICS	SYMBOL	SF21	SF22	SF23	SF24	SF25	SF26	SF27	UNITS
Maximum Forward Voltage at 2.0A DC	VF	0.95			1.25		1.70		Volts
Maximum DC Reverse Current @ TA = 25°C	IR	5.0							uAmps
at Rated DC Blocking Voltage @ TA =100°C		100							
Maximum Reverse Recovery Time (Note 1)	trr	35			50				nSec

NOTES : 1. Test Conditions: IF=0.5A, IR=-1.0A, IRR=-0.25A.
 2. Measured at 1 MHz and applied reverse voltage of 4.0 volts.

RATING AND CHARACTERISTIC CURVES (SF21 THRU SF27)

FIG. 1 - TEST CIRCUIT DIAGRAM AND REVERSE RECOVERY TIME CHARACTERISTIC

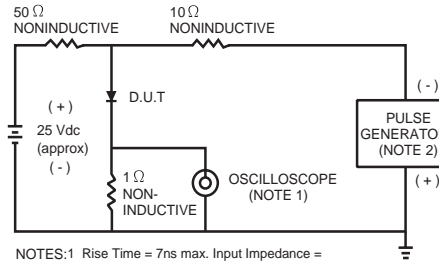

NOTES: 1. Rise Time = 7ns max. Input Impedance = 1 megohm, 22pF.
2. Rise Time = 10ns max. Source Impedance = 50 ohms.

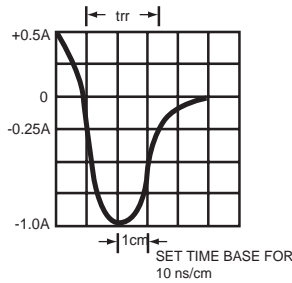

FIG. 2 - TYPICAL FORWARD CURRENT DERATING CURVE

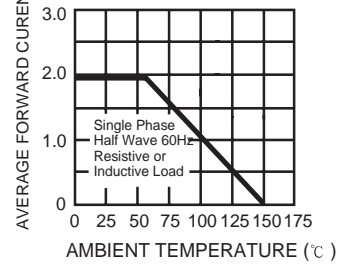

FIG. 3 - TYPICAL REVERSE CHARACTERISTICS

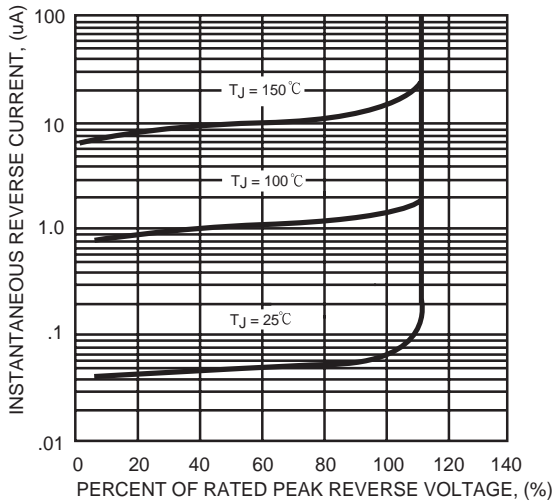

FIG. 4 - TYPICAL INSTANTANEOUS FORWARD CHARACTERISTICS

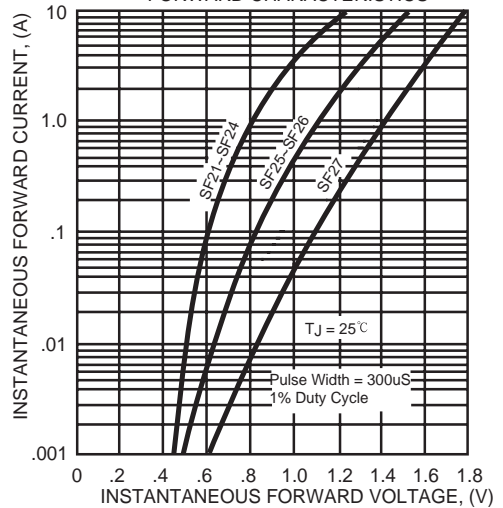

FIG. 5 - MAXIMUM NON-REPETITIVE FORWARD SURGE CURRENT

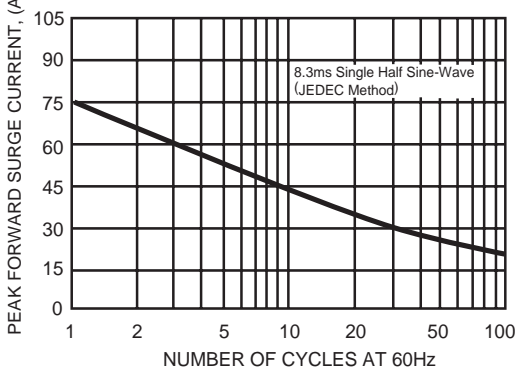

FIG. 6 - TYPICAL JUNCTION CAPACITANCE

