

**GLASS PASSIVATED SUPER FAST RECTIFIER**

**VOLTAGE RANGE 50 to 600 Volts CURRENT 1.0 Ampere**

**FEATURES**

- \* High reliability
- \* Low leakage
- \* Low forward voltage
- \* High current capability
- \* Super fast switching speed
- \* High surge capability
- \* Good for switching mode circuit

**MECHANICAL DATA**

- \* Case: Molded plastic
- \* Epoxy: Device has UL flammability classification 94V-0
- \* Lead: MIL-STD-202E method 208C guaranteed
- \* Mounting position: Any
- \* Weight: 0.33 gram

**MAXIMUM RATINGS AND ELECTRICAL CHARACTERISTICS**

Ratings at 25 °C ambient temperature unless otherwise specified.  
 Single phase, half wave, 60 Hz, resistive or inductive load.  
 For capacitive load, derate current by 20%.

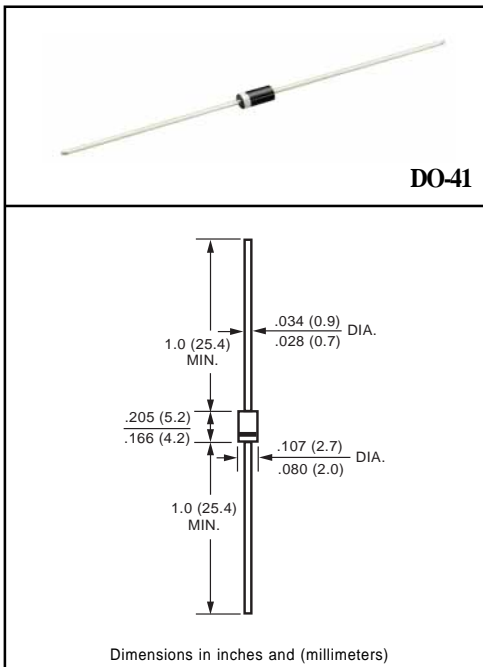

**MAXIMUM RATINGS** (At TA = 25°C unless otherwise noted)

RATINGS	SYMBOL	SF11	SF12	SF13	SF14	SF15	SF16	SF17	UNITS	
Maximum Recurrent Peak Reverse Voltage	VRRM	50	100	150	200	300	400	600	Volts	
Maximum RMS Volts	VRMS	35	70	105	140	210	280	420	Volts	
Maximum DC Blocking Voltage	VDC	50	100	150	200	300	400	600	Volts	
Maximum Average Forward Current at TA = 55°C	Io	1.0							Amps	
Peak Forward Surge Current IFM (surge):8.3 ms single half sine-wave superimposed on rated load (JEDEC method)	IFSM	30							Amps	
Typical Junction Capacitance (Note 2)	Cj	15				10			pF	
Operating and Storage Temperature Range	TJ, TSTG	-55 to +150								°C

**ELECTRICAL CHARACTERISTICS** (At TA = 25°C unless otherwise noted)

CHARACTERISTICS	SYMBOL	SF11	SF12	SF13	SF14	SF15	SF16	SF17	UNITS
Maximum Forward Voltage at 1.0A DC	Vf	0.95			5.0		1.25	1.70	Volts
Maximum DC Reverse Current at Rated DC Blocking Voltage	@ TA = 25°C	IR							uAmps
	@ TA =100°C								
Maximum Reverse Recovery Time (Note 1)	trr	35						50	nSec

NOTES : 1. Test Conditions: IF=0.5A, IR=-1.0A, IRR=-0.25A.  
 2. Measured at 1 MHz and applied reverse voltage of 4.0 volts.

# RATING AND CHARACTERISTIC CURVES ( SF11 THRU SF17 )

FIG. 1 - TEST CIRCUIT DIAGRAM AND REVERSE RECOVERY TIME CHARACTERISTIC

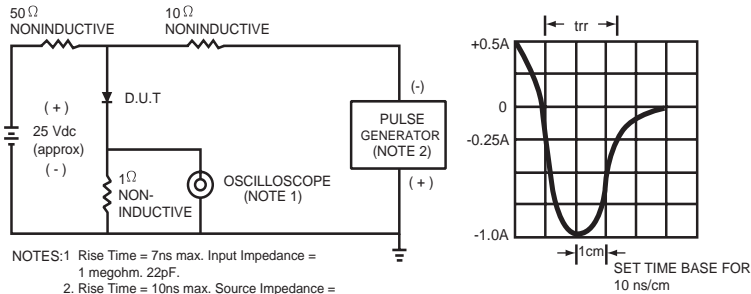

FIG. 2 - TYPICAL FORWARD CURRENT DERATING CURVE

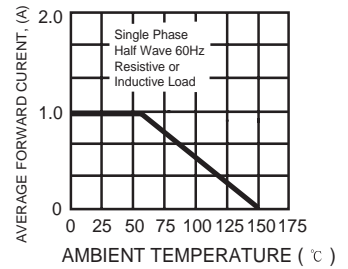

FIG. 3 - TYPICAL REVERSE CHARACTERISTICS

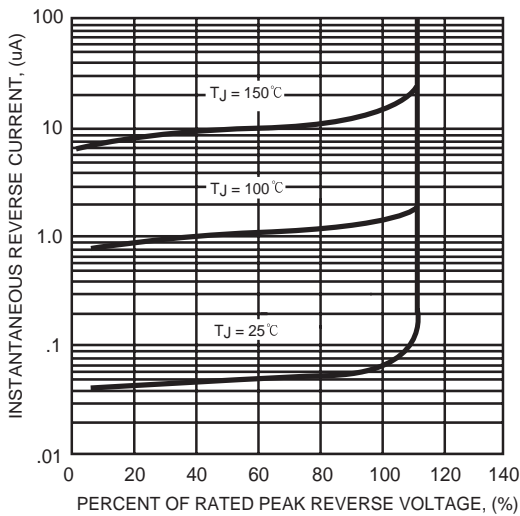

FIG. 4 - TYPICAL INSTANTANEOUS FORWARD CHARACTERISTICS

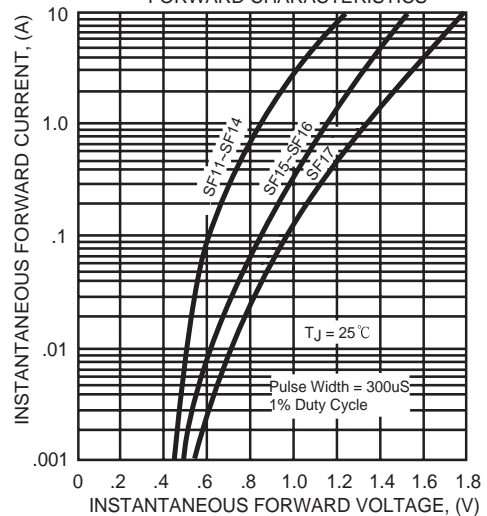

FIG. 5 - MAXIMUM NON-REPETITIVE FORWARD SURGE CURRENT

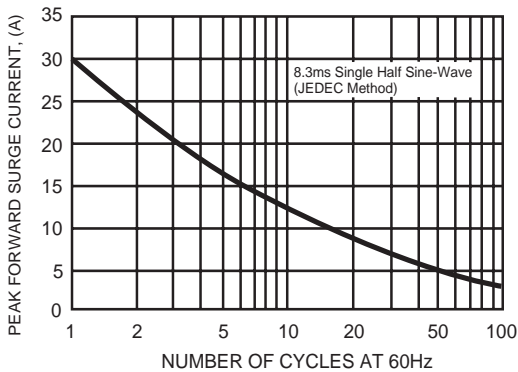

FIG. 6 - TYPICAL JUNCTION CAPACITANCE

