

SURFACE MOUNT SILICON RECTIFIER

VOLTAGE RANGE 50 to 1000 Volts CURRENT 1.0 Ampere

FEATURES

- * Ideal for surface mounted applications
- * Low leakage current
- * Metallurgically bonded construction
- * Mounting position: Any
- * Weight: 0.057 gram

MECHANICAL DATA

- * Epoxy : Device has UL flammability classification 94V-0

MAXIMUM RATINGS AND ELECTRICAL CHARACTERISTICS

Ratings at 25 °C ambient temperature unless otherwise specified.
Single phase, half wave, 60 Hz, resistive or inductive load.
For capacitive load, derate current by 20%.

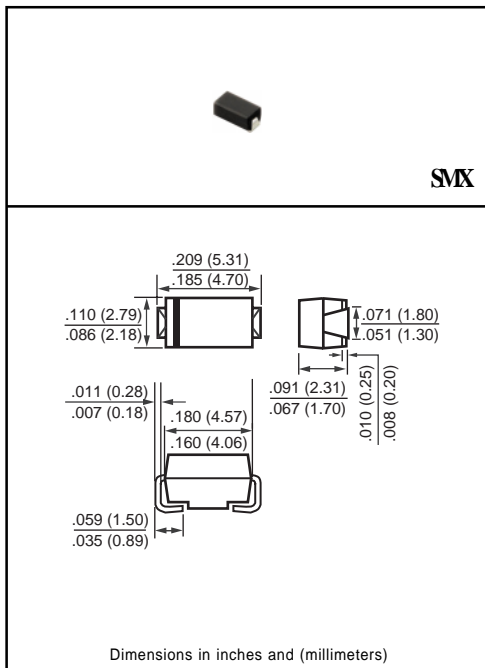

Dimensions in inches and (millimeters)

MAXIMUM RATINGS (At TA = 25°C unless otherwise noted)

RATINGS	SYMBOL	FM4001W	FM4002W	FM4003W	FM4004W	FM4005W	FM4006W	FM4007W	UNITS
Maximum Recurrent Peak Reverse Voltage	VRRM	50	100	200	400	600	800	1000	Volts
Maximum RMS Voltage	VRMS	35	70	140	280	420	560	700	Volts
Maximum DC Blocking Voltage	Vdc	50	100	200	400	600	800	1000	Volts
Maximum Average Forward Rectified Current at TA = 75°C	Io	1.0							Amps
Peak Forward Surge Current IFM(surge): 8.3 ms single half sine-wave superimposed on rated load (JEDEC method)	IFSM	30							Amps
Maximum Thermal Resistance	(Note 2) RθJL	60							°C/W
	(Note 3) RθJA	100							°C/W
Typical Junction Capacitance (Note 1)	CJ	15							pF
Operating and Storage Temperature Range	TJ, TSTG	-55 to + 150							°C

ELECTRICAL CHARACTERISTICS (At TA = 25°C unless otherwise noted)

CHARACTERISTICS	SYMBOL	FM4001W	FM4002W	FM4003W	FM4004W	FM4005W	FM4006W	FM4007W	UNITS
Maximum Forward Voltage at 1.0A DC	VF	1.1							Volts
Maximum Full Load Reverse Current, Full cycle Average at TA=75°C	IR	30							uAmps
Maximum DC Average Reverse Current at @TA = 25°C		5.0							uAmps
Rated DC Blocking Voltage @TA = 125°C		50							uAmps

- NOTES : 1. Measured at 1.0 MHz and applied average voltage of 4.0VDC
2. Thermal resistance junction to terminal 6.0mm² copper pads to each terminal.
3. Thermal resistance junction to ambient, 6.0mm² copper pads to each terminal.
4. "Fully ROHS compliant", "100% Sn plating (Pb free).

RATING AND CHARACTERISTIC CURVES (FM4001W THRU FM4007W)

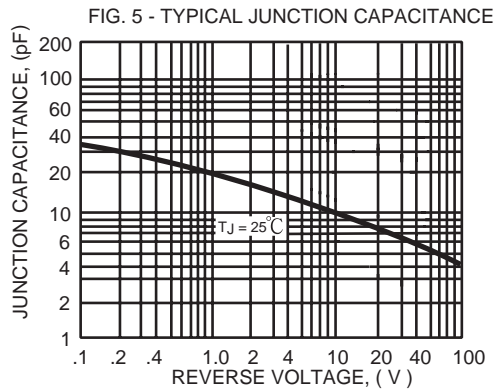
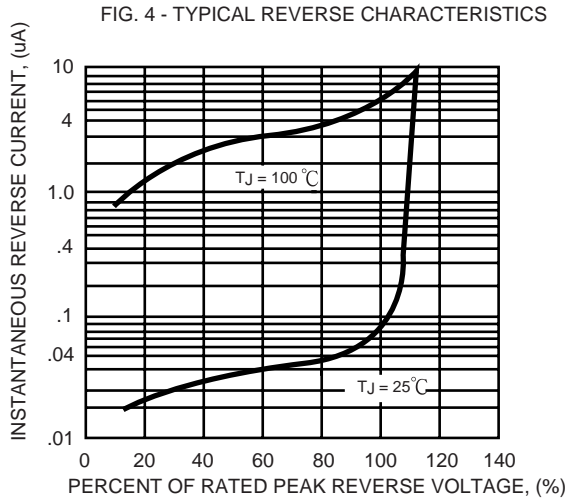
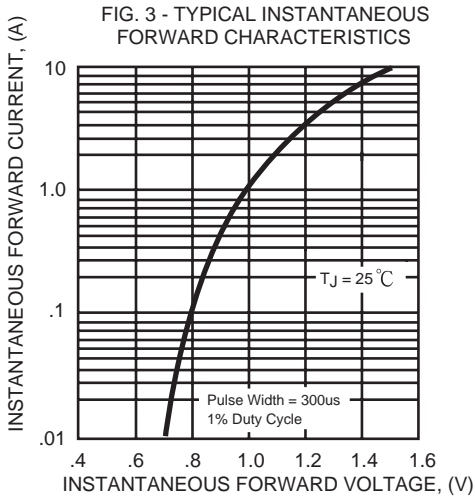
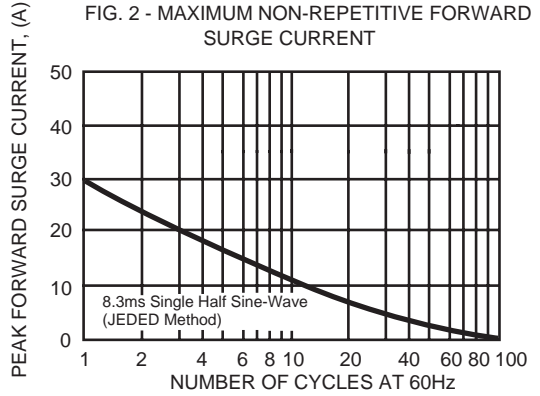
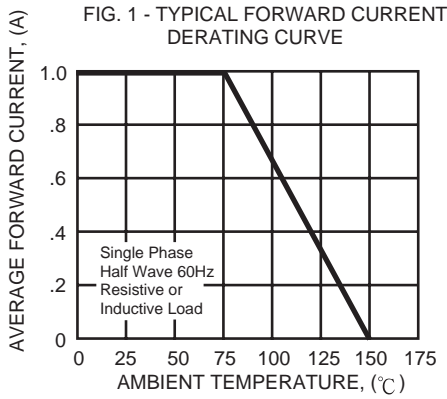

Mounting Pad Layout

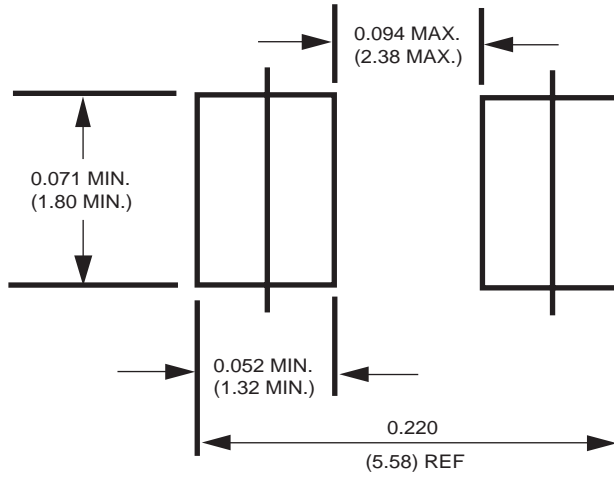

Dimensions in inches and (millimeters)