

# REEL TAPING SPECIFICATIONS FOR SURFACE MOUNT DEVICES-FLAT MELF ( SMA/SMB/SMC )

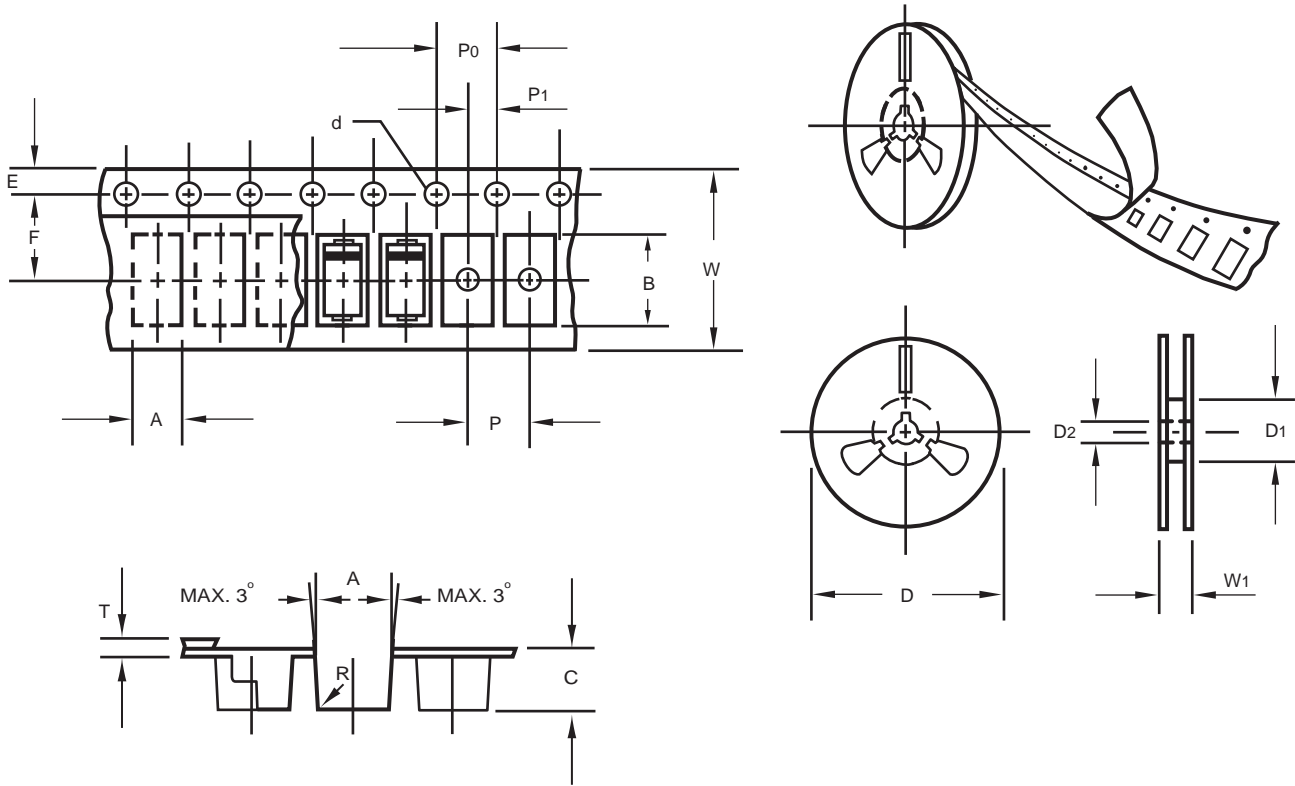

Fig.: Configuration of FLAT MELF TAPING  
( SMA/SMB/SMC )

ITEM	SYMBOL	DO214AC (SMA) mm(inch)	DO214AA (SMB) mm(inch)	DO214AB (SMC) mm(inch)
Carrier width	A	2.6 ± 0.15 (.102 ± .006)	3.65 ± 0.1 (.144 ± .004)	6.0 ± 0.1 (.236 ± .004)
Carrier length	B	5.15 ± 0.15 (.203 ± .006)	5.69 ± 0.1 (.224 ± .004)	8.30 ± 0.1 (.327 ± .004)
Carrier depth	C	2.3 ± 0.15 (.091 ± .006)	2.67 ± 0.1 (.105 ± .004)	2.5 ± 0.1 (.098 ± .004)
Sprocket hole	d	1.5 ± 0.1 (.059 ± .004)	1.5 ± 0.1 (.059 ± .004)	1.5 ± 0.1 (.059 ± .004)
Reel outside diameter	D	178 ± 2.0 (7.0 ± .079)	178 ± 2.0 (7.0 ± .079)	178 ± 2.0 (7.0 ± .079)
Reel inner diameter	D1	50 Min.	50 Min.	50 Min.
Feed hole diameter	D2	13 ± 0.5 (.512 ± .020)	13 ± 0.5 (.512 ± .020)	13 ± 0.5 (.512 ± .020)
Strocket hole position	E	1.5 ± 0.1 (.059 ± .004)	1.5 ± 0.1 (.059 ± .004)	1.5 ± 0.1 (.059 ± .004)
Punch hole position	F	5.65 ± 0.05 (.222 ± .002)	5.65 ± 0.05 (.222 ± .002)	7.65 ± 0.05 (.301 ± .002)
Punch hole pitch	P	4.0 ± 0.1 (.157 ± .004)	8.0 ± 0.1 (.315 ± .004)	8.0 ± 0.1 (.315 ± .004)
Sprocket hole pitch	P0	4.0 ± 0.1 (.157 ± .004)	4.0 ± 0.1 (.157 ± .004)	4.0 ± 0.1 (.157 ± .004)
Embossment center	P1	2.0 ± 0.1 (.079 ± .004)	2.0 ± 0.1 (.079 ± .004)	4.0 ± 0.1 (.157 ± .004)
Total tape thickness	T	0.30 ± .05 (.012 ± .002)	0.6 Max.	0.6 Max.
Tape width	W	12.0 ± 0.2 (.472 ± .008)	12.0 ± 0.2 (.472 ± .008)	16.0 ± 0.2 (.630 ± .008)
Reel width	W1	16.8 ± 2.0 (.661 ± .079)	16.8 ± 2.0 (.661 ± .079)	24.0 ± 2.0 (.945 ± .079)

Notes: 1.Devices are packed in accordance with EIA standard RS-481-A and specification given above.  
2.Available on 7 inch ( 1500 ct. ) or 13 inch ( 5000 ct. ) diameter reels.